

Drill Stands KF 600

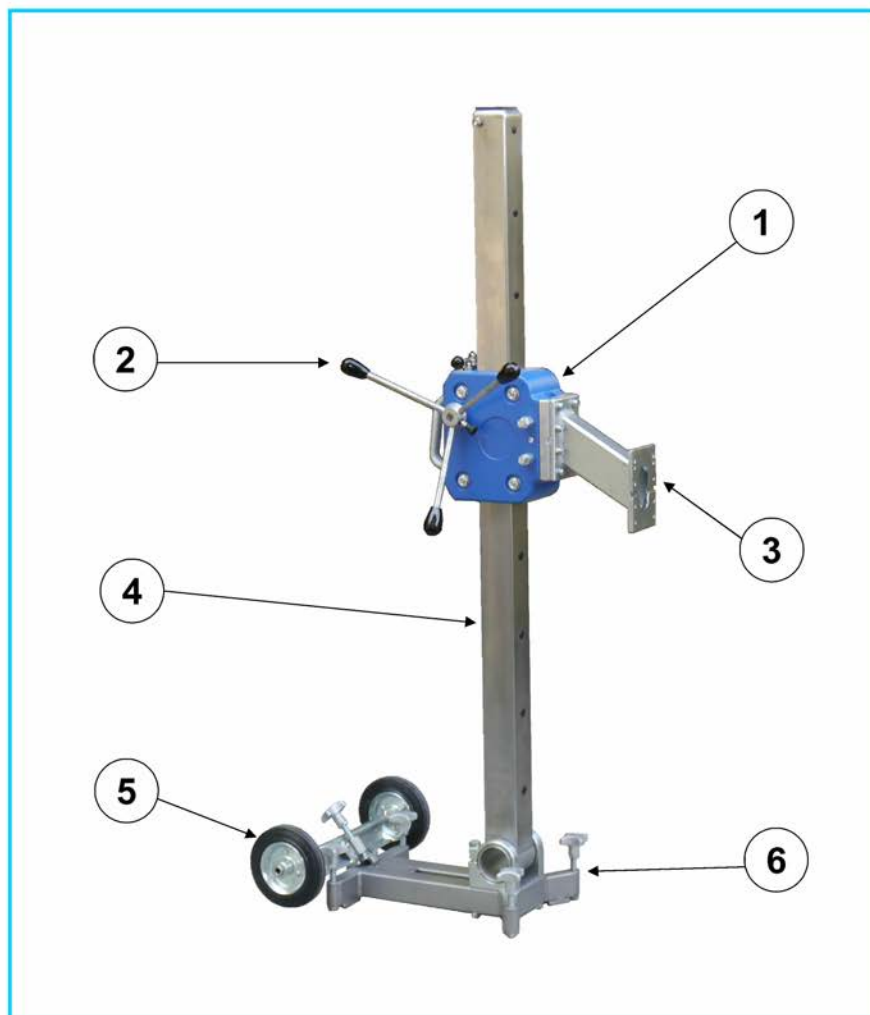

Item	Designation	Order no.	Piece	Price/Piece
	Drill KF 600 with colour cpl.	KF 600.F	1	
1	Carriage with colour cpl.	601.1.0 KF K F	1	
2	Crank cpl.	250.2.0 K	1	
3	Spacer 170 mm cpl.	600.2.0 K	1	
4	Column 1400 mm with flexible bracket cpl.	600.6.014 G.K	1	
5	Wheel Kit cpl.	600.1.06 K	1	
6	Foot plate steel cpl.	600.4.0 ST.K	1	

Drill Stands KF 600

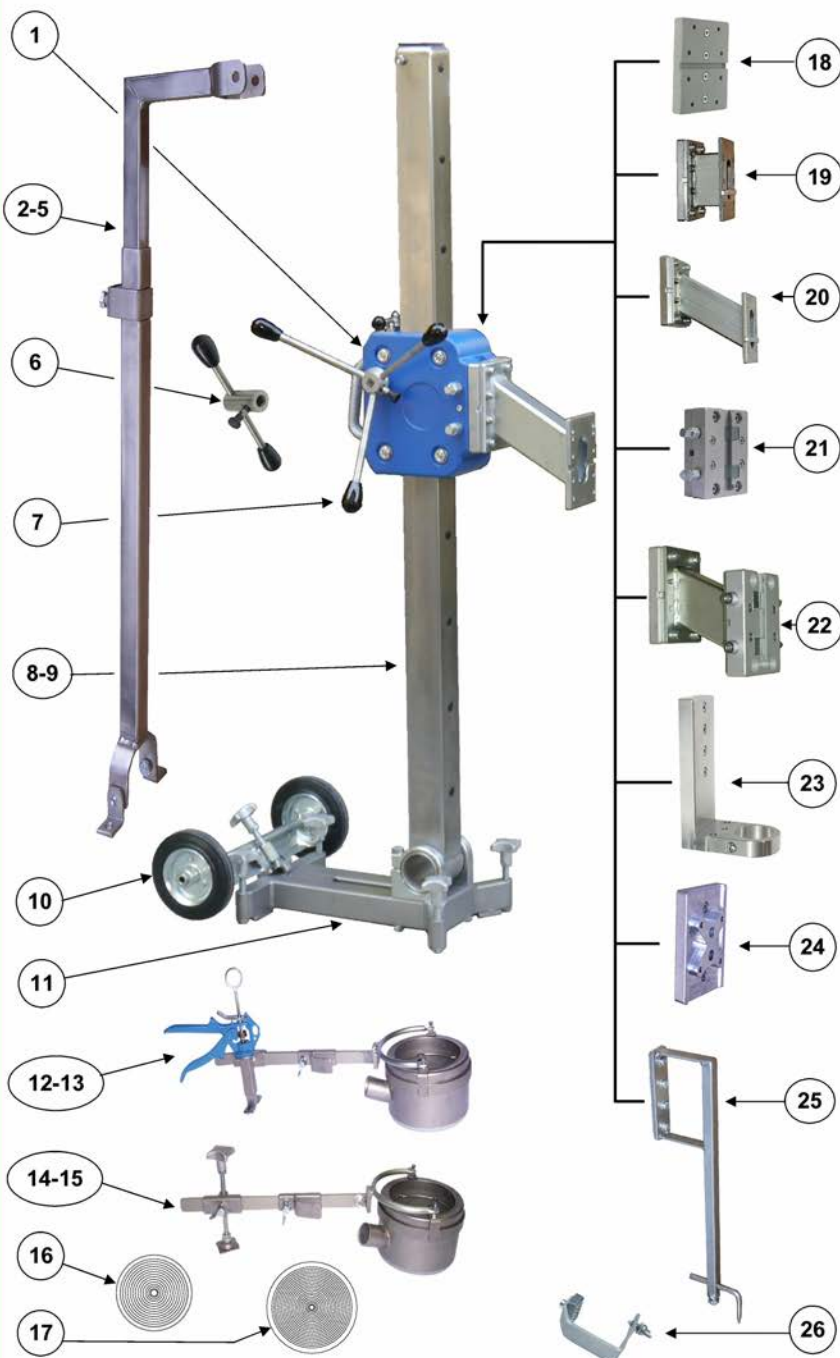

components and parts list KF 600

Item	Designation	Order no.	Piece	Price/Piece
1	Carriage with colour cpl.	601.1.0 KF	1	
2	Support 1400 mm cpl.	400.19.00 K	1	
3	Support 2000 mm cpl.	400.20.00 K	1	
4	Support 1400 mm for retrofiting	400.22.00 K	1	
5	Support 2000 mm for retrofiting	400.23.00 K	1	
6	Spring lever crank cpl.	600.3.0 K	1	
7	Crank cpl.	250.2.0 K	1	
8	Column 1400 mm with flexible bracket cpl.	600.6.014 G.K	1	
9	Column 2000 mm with flexible bracket cpl.	600.6.020 G.K	1	
10	Wheel Kit cpl.	600.1.06 K	1	
11	Foot plate steel cpl.	600.4.0 ST.K	1	
12	Drill water scution ring + chuck handle D132 cpl.	250.8.0 K	1	
13	Drill water scution ring + chuck handle D202 cpl.	250.9.0 K	1	
14	Drill water suction ring + chuck screw D132 cpl.	250.8.01 K	1	
15	Drill water suction ring + chuck screw D202 cpl.	250.9.01 K	1	
16	Membrane D 132	150.8.7	1	
17	Membrane D 202	250.8.7	1	
18	Drilling motor plate cpl.	600.1.18 K	1	
19	Spacer 110 mm cpl.	400.2.0 BD K	1	
20	Spacer 190 mm cpl.	600.2.0 BD K	1	
21	Quick change distance piece 50 mm cpl.	600.1.19 BG K	1	
22	Quick change distance piece 170 mm cpl.	600.2.01 BDG K	1	
23	Instep neck adapter cpl.	150.11.0 K	1	
24	Motor plate for Hilti Engines cpl.	400.1.18 H K	1	
25	Drilling middles indicator, m.d. 115-150 mm cpl.	250.10.2 K	1	
26	End stop cpl.	250.6.30 K	1	

Copyright © 2015 by FleiKa Maschinen- und Anlagenbau GmbH & Co KG

Information: We reserve to make changes of our Drill stands.

Carriage KF 600

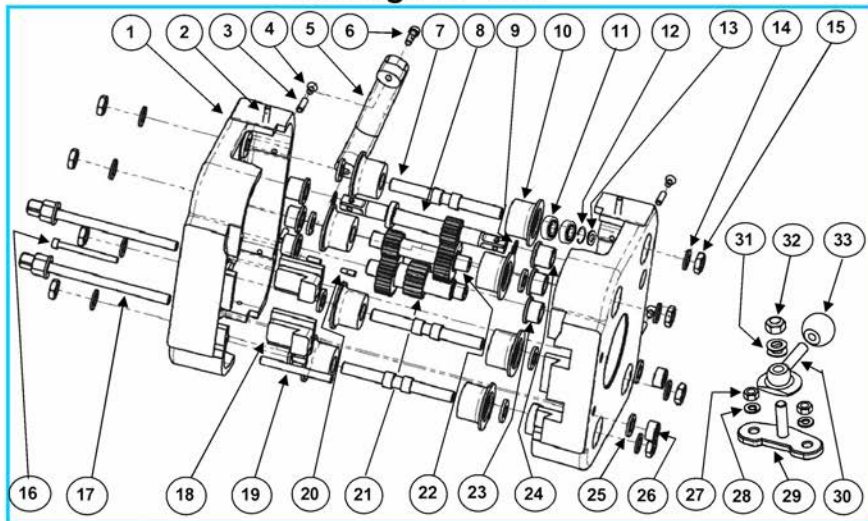

Item	Designation	Order no.	Piece	Price/Piece
	Carriage cpl. with colour	601.1.0 KF K F	1	
1	housing left or right with colour	250.1.1 KF F	2	
2	covering screw I6kt. M 6x22	250.1.27	2	
3	grub screw I6kt M 6x20	250.1.11	4	
4	covering screw M 6x8	250.1.12	4	
5	handle	250.1.13	1	
6	covering screw M 6x25	250.1.14	2	
7	axis	600.1.2	4	
8	spline shaft	250.1.7	1	
9	spacer washer D 16x1,5 mm	250.1.9	2	
	Rollers with ball bearing cpl.	600.1.5 K	8	
10	rollers	600.1.5	8	
11	ball bearing D 32x12	250.1.6	8	
12	snap ring D 32	250.1.5.1	8	
13	washer for ball bearing	600.1.4.1	8	
14	spring washer D 12	250.1.4	8	
15	nut flat M 12x7	250.1.3	8	
16	covering screw M 6x65	250.1.31	1	
17	adjusting screw M 10x131	250.1.15	2	
18	stretching block	250.1.16	2	
19	clamping pin 8x80	250.1.24	1	
20	clamping pin 5x16	250.1.25	4	
21	twin spine shift	250.1.22	1	
22	twin spine shift	600.1.22	1	
23	bearing bush D16xD22x16mm	250.1.23	4	
24	bearing bush D16xD22x20mm	150.1.10	2	
25	washer D 10	150.5.6	4	
26	adjusting ring M 10	150.1.28	2	

	Feed locking cpl.	250.3.10 K	1	
27	nut self locking M 6	250.3.7	2	
28	washer D 6	250.3.8	2	
29	feed locking	250.3.11	1	
30	turn plate	250.3.12	1	
31	spring washer D 8	250.1.29	2	
32	nut self locking M 8	250.3.14	1	
33	ball handle	250.3.13	1	

Support KF 600

2-3

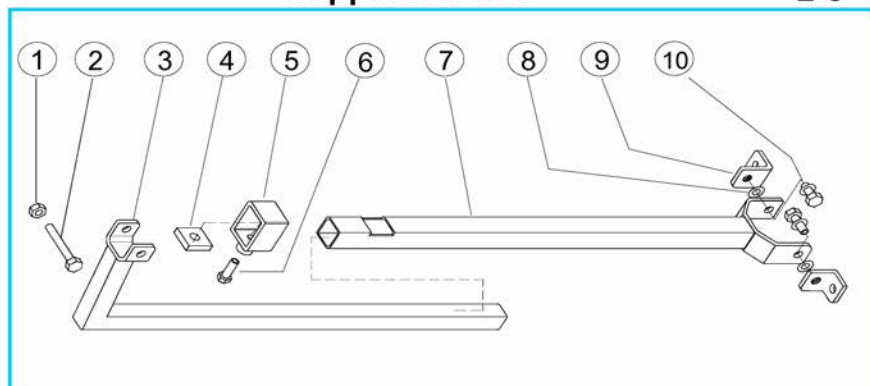

Support 1400 mm

2

Item	Designation	Order no.	Piece	Price/Piece
1	hexagon nut M 10	250.6.12	1	
2	hexagon screw M 10x95	400.18.04	1	
3	supporting tube 30x30x1130 mm	400.19.01	1	
4	thrust collar 30x35xD12	400.18.06	1	
5	clamp 37x45 mm	400.18.03	1	
6	hexagon screw M 12x30	400.18.05	1	
7	supporting sleeve 35x35x530 mm	400.18.02	1	
8	spring washer D 10	250.16.05	6	
9	mounting bracket M 10 40x35	250.18.08	2	
10	hexagon screw M 10x16	250.18.07	4	

Support 2000 mm

3

Item	Designation	Order no.	Piece	Price/Piece
1	hexagon nut M 10	250.6.12	1	
2	hexagon screw M 10x95	400.18.04	1	
3	supporting tube 30x30x1730 mm	400.20.01	1	
4	thrust collar 30x35xD12	400.18.06	1	
5	clamp 37x45 mm	400.18.03	1	
6	hexagon screw M 12x30	400.18.05	1	
7	supporting sleeve 35x35x530 mm	400.18.02	1	
8	spring washer D 10	250.16.05	6	
9	mounting bracket M 10 40x35	250.18.08	2	
10	hexagon screw M 10x16	250.18.07	4	

4-5 Support KF 600 for retrofitting

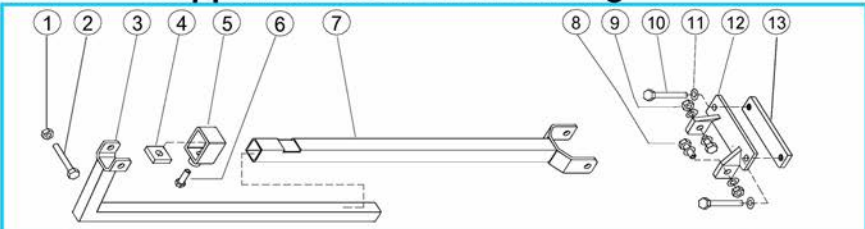

4 Support 1400 mm for retrofitting

Item	Designation	Order no.	Piece	Price/Piece
1	hexagon nut M 10	250.6.12	1	
2	hexagon screw M 10x95	400.18.04	1	
3	supporting tube 30x30x1130 mm	400.19.01	1	
4	thrust collar 30x35xD12	400.18.06	1	
5	clamp 37x45 mm	400.18.03	1	
6	hexagon screw M 12x30	400.18.05	1	
7	supporting sleeve 35x35x530 mm	400.18.02	1	
8	hexagon screw M 10x30	250.16.15	2	
9	nut M 10	250.6.12	2	
10	hexagon screw M 10x65	250.15.17	2	
11	spring washer D 10	250.16.05	6	
12	foot clamping part 155x40x82 mm	250.16.16	1	
13	foot clamping part 155x30 mm	250.16.18	1	

5 Support 2000 mm for retrofitting

Item	Designation	Order no.	Piece	Price/Piece
1	hexagon nut M 10	250.6.12	1	
2	hexagon screw M 10x95	400.18.04	1	
3	supporting tube 30x30x1730 mm	400.20.01	1	
4	thrust collar 30x35xD12	400.18.06	1	
5	clamp 37x45 mm	400.18.03	1	
6	hexagon screw M 12x30	400.18.05	1	
7	supporting sleeve 35x35x530 mm	400.18.02	1	
8	hexagon screw M 10x30	250.16.15	2	
9	nut M 10	250.6.12	2	
10	hexagon screw M 10x65	250.15.17	2	
11	spring washer D 10	250.16.05	6	
12	foot clamping part 155x40x82 mm	250.16.16	1	
13	foot clamping part 155x30 mm	250.16.18	1	

6 Single lever crank cpl. KF 600

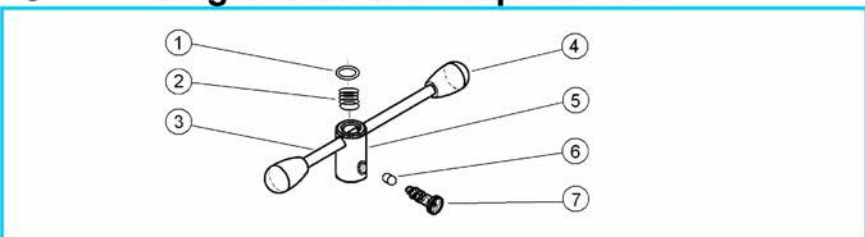

Item	Designation	Order no.	Piece	Price/Piece
1	spring D 10	600.3.3	2	
2	feather	600.3.4	1	
3	roundmaterial D 12x300 mm	600.3.2	1	
4	ball handle	250.2.3	2	
5	hub	600.3.1	1	
6	distancing D 10	600.3.5	1	
7	stop bolt	250.2.2	1	

Crank cpl. KF 600

7

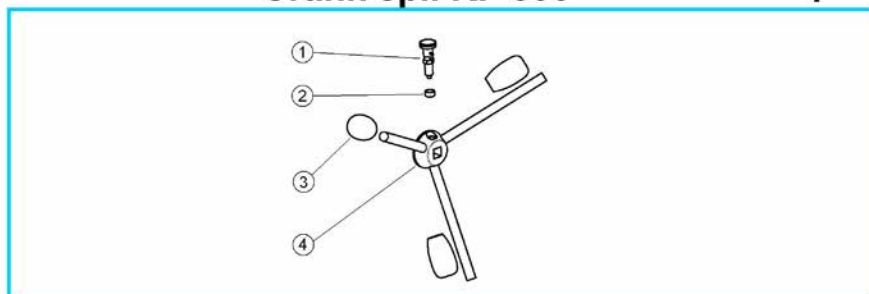

Item	Designation	Order no.	Piece	Price/Piece
1	stop bolt	250.2.2	1	
2	spacer ring	250.2.4	1	
3	ball handle	250.2.3	3	
4	crank body	150.2.1	1	

Column cpl. KF 400-600

8-9

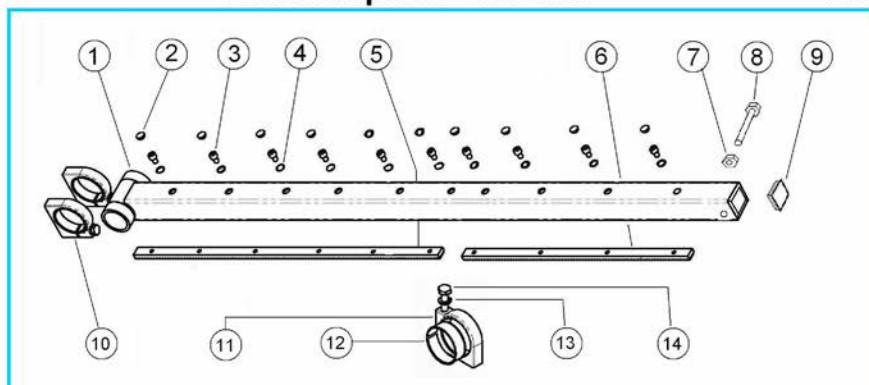

Column LG 1400 cpl. with flexible bracket

8

Item	Designation	Order no.	Piece	Price/Piece
	Column 1400 cpl. with flexible bracket	600.6.014 G.K	1	
1	guide bar 70x1400 mm	600.6.1.14	1	
2	blindlystopset D 13	250.6.5	10	
3	screw M 8x12	250.6.3	10	
4	retainer ring D 8	250.6.4	10	
5	gear rack Mo.2x790 mm	250.6.2	1	
6	gear rack Mo.2x484 mm	600.6.21	1	
7	fixing nut M 10	250.6.12	2	
8	screw stop M 10x80	250.6.11	1	
9	cover cap	250.6.17	1	
10	Flexible bracket cpl.	650.5.0 K	2	
11	flexible bracket	250.5.1	2	
12	brass ring	250.5.2	2	
13	washer D 12	250.5.6	2	
14	clamping bolt M 12x50	250.5.4	2	

9

Column cpl. KF 400-600

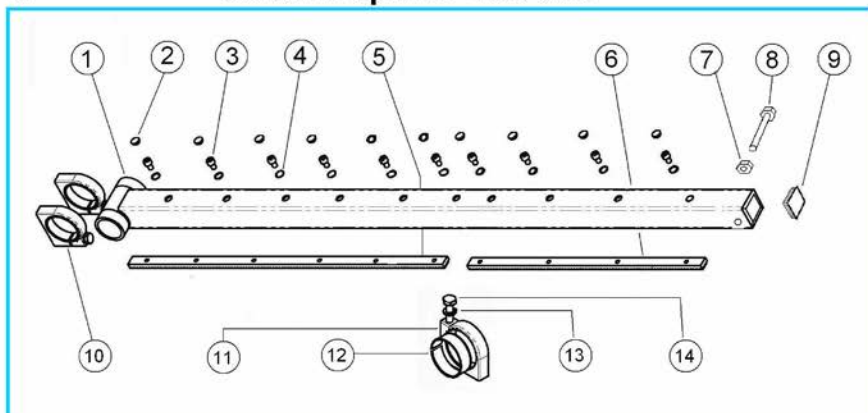

9

Column LG 2000 cpl. with flexible bracket

Item	Designation	Order no.	Piece	Price/Piece
	Column 2000 cpl. with flexible bracket	600.6.020 G.K	1	
1	guid bar 70x2000 mm	600.6.1.20	1	
2	blindlystoppel D 13	250.6.5	14	
3	screw M 8x12	250.6.3	14	
4	retainer ring D 8	250.6.4	14	
5	gear rack Mo.2x790 mm	250.6.2	2	
6	gear rack Mo.2x306 mm	600.6.22	1	
7	fixing nut M 10	250.6.12	2	
8	screw stop M 10x80	250.6.11	1	
9	cover cap	250.6.17	1	
10	Flexible bracket cpl.	600.5.0 K	2	
11	flexible bracket	250.5.1	2	
12	brass ring	250.5.2	2	
13	washer D 12	250.5.6	2	
14	clamping bolt M 12x50	250.5.4	2	

10

Wheel kit KF 600

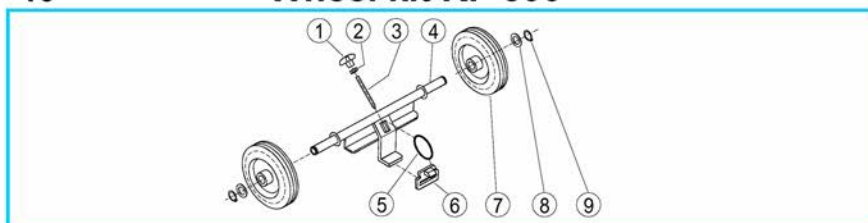

Item	Designation	Order no.	Piece	Price/Piece
1	star knob M 12	250.3.5	1	
2	nut flat M 12x7	250.1.3	1	
3	threaded bolts M 12	250.4.14	1	
4	wheel kit body	600.1.07	1	
5	clamping rubber	250.4.13	1	
6	span clump	250.4.12	1	
7	wheels D 160	250.4.8	2	
8	washer D 20	250.4.9	2	
9	snap rings D 20	250.4.10	2	

Foot plate steel cpl. KF 600

11

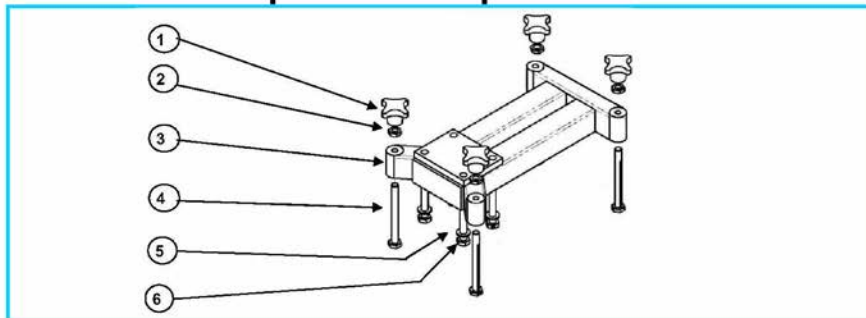

Item	Designation	Order no.	Piece	Price/Piece
1	star knob M 12	250.4.3	4	
2	nut flat M 12x7	250.1.3	4	
3	foot plate body	600.4.1 ST	1	
4	adjusting screw	250.4.2	4	
5	retainer ring D 12	250.5.5	4	
6	screw M 12x70	600.5.3	4	

Drill water suction ring + chuck handle KF 600 12-13

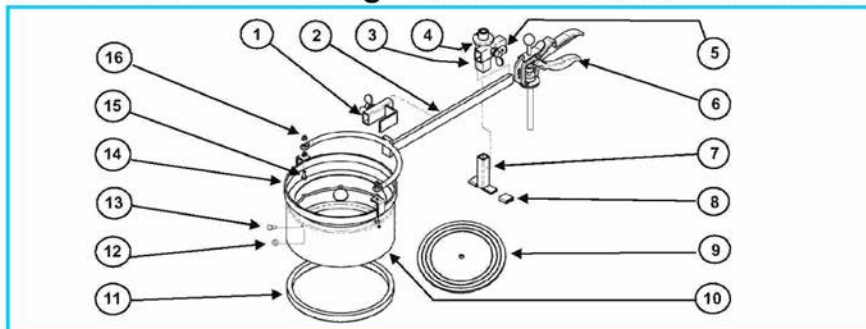

Drill water suction ring D 132 + chuck handle

12

Item	Designation	Order no.	Piece	Price/Piece
1	thrust fork	250.9.7	1	
2	chuck fork D 132	150.8.3	1	
3	bracing device	250.9.2	1	
4	screw M 6x12	150.6.3	2	
5	thumb screw M 10x20	250.9.9	2	
6	chuck handle	250.9.1	1	
7	pressure piece	250.9.8	1	
8	rubber sleeves for pressure piece	250.9.13	2	
10	collecting ring D 132	150.8.4	1	
11	sealing rubber D 132	150.8.6	1	
12	nut M 4	250.9.12	3	
13	cylinder screw M 4x6	250.9.11	3	
14	retaining ring D 132	150.8.5	1	
15	screw M 6x25	250.9.10	2	
16	nut flat M 6	250.3.7	4	

13 Drill water suction ring D 202 + chuck handle

Item	Designation	Order no.	Piece	Price/Piece
1	thrust fork	250.9.7	1	
2	chuck fork D 202	250.9.3	1	
3	bracing device	250.9.2	1	
4	screw M 6x12	150.6.3	2	
5	thumb screw M 10x20	250.9.9	2	
6	chuck handle	250.9.1	1	
7	pressure piece	250.9.8	1	
8	rubber sleeves for pressure piece	250.9.13	2	
10	collecting ring D 202	250.9.4	1	
11	sealing rubber D 202	250.9.6	1	
12	nut M 4	250.9.12	4	
13	cylinder screw M 4x6	250.9.11	4	
14	retaining ring D 202	250.9.5	1	
15	screw M 6x25	250.9.10	2	
16	nut flat M 6	250.3.7	4	

14-15 Drill water suction ring + chuck screw

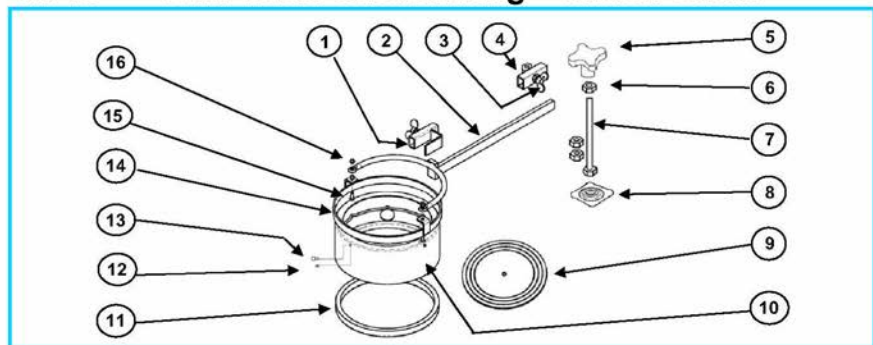

14 Drill water suction ring D 132 + chuck screw

Item	Designation	Order no.	Piece	Price/Piece
1	thrust fork	250.9.7	1	
2	chuck fork D 132	150.8.3	1	
3	thumb screw M 10x20	250.9.9	2	
4	chuck screw	250.9.15	1	
5	alu cross handle M 12	250.4.3	1	
6	hexagon screw flat M 12x7	250.1.3	3	
7	screw M 12x160	250.9.16	1	
8	supporting plate D 12	250.9.17	1	
10	collecting ring D 132	150.8.4	1	
11	sealing rubber D 132	150.8.6	1	
12	nut M 4	250.9.12	3	
13	cylinder screw M 4x6	250.9.11	3	
14	retaining ring D 132	150.8.5	1	
15	screw M 6x25	250.9.10	2	
16	nut flat M 6	250.3.7	4	

Drill water suction ring D 202 + chuck screw

15

Item	Designation	Order no.	Piece	Price/Piece
1	thrust fork	250.9.7	1	
2	chuck fork D 202	250.9.3	1	
3	thumb screw M 10x20	250.9.9	2	
4	chuck screw	250.9.15	1	
5	alu cross handle M 12	250.4.3	1	
6	hexagon screw flat M 12x7	250.1.3	3	
7	screw M 12x160	250.9.16	1	
8	supporting plate D 12	250.9.17	1	
10	collecting ring D 202	250.9.4	1	
11	sealing rubber D 202	250.9.6	1	
12	nut M 4	250.9.12	4	
13	cylinder screw M 4x6	250.9.11	4	
14	retaining ring D 202	250.9.5	1	
15	screw M 6x25	250.9.10	2	
16	nut flat M 6	250.3.7	4	

16-17

9	Membrane D 132	150.8.7	1	
9	Membrane D 202	250.8.7	1	

Drilling motor plate KF 600

18

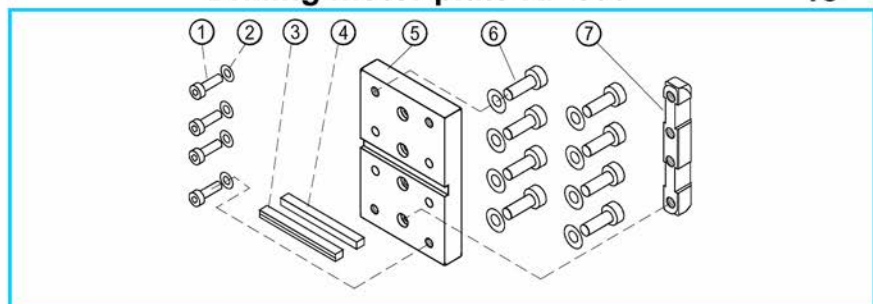

Item	Designation	Order no.	Piece	Price/Piece
1	hexagonal screw M 8x20 / 12.9	700.1.21	4	
2	spring washer D 8	250.1.29	12	
3	feather 9,5x8x100 mm	250.1.20	1	
4	feather 10x8x100 mm	250.1.19	1	
5	drilling motor plate	700.1.18	1	
6	hexagonal screw M 8x30	250.1.30	8	
7	straining beam	250.1.17	1	

19

Spacer 110 mm cpl. KF 600

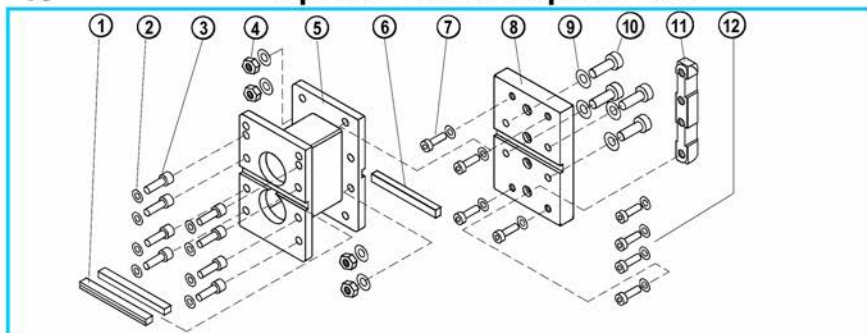

Item	Designation	Order no.	Piece	Price/Piece
	Spacer 90 mm cpl.	400.2.0 K	1	
1	feather 9,5x8x100 mm	250.1.20	1	
2	spring washer D 8	250.1.29	12	
3	hexagonal screw M 8x30	250.1.30	8	
4	hexagonal self-locking nut M 8	250.3.14	4	
5	spacer body 90 mm	400.2.0	1	
6	feather 10x8x100 mm	250.1.19	1	
	Drilling motor plate cpl.	600.1.18 BD K	1	
7	hexagonal screw M 8x25	150.1.30	4	
8	Drilling motor plate	600.1.18	1	
9	spring washer D 8	250.1.29	12	
10	hexagonal screw M 8x30	250.1.30	4	
11	Clamping bolt	250.1.17	1	
12	hexagonal screw M 8x20 / 12.9	250.1.21	4	

20

Spacer 190 mm cpl. KF 600

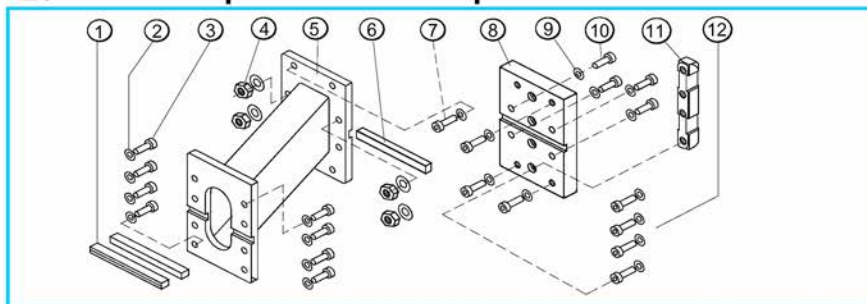

Item	Designation	Order no.	Piece	Price/Piece
	Spacer 170 mm cpl.	600.2.0 K	1	
1	feather 9,5x8x100 mm	250.1.20	1	
2	spring washer D 8	250.1.29	12	
3	hexagonal screw M 8x30	250.1.30	8	
4	hexagonal self-locking nut M 8	250.3.14	4	
5	spacer body 170 mm	600.2.0	1	
6	feather 10x8x100 mm	250.1.19	2	
	Drilling motor plate cpl.	600.1.18 BD K	1	
7	hexagonal screw M 8x25	150.1.30	4	
8	Drilling motor plate	600.1.18	1	
9	spring washer D 8	250.1.29	12	
10	hexagonal screw M 8x30	250.1.30	4	
11	Clamping bolt	250.1.17	1	
12	hexagonal screw M 8x20 / 12.9	250.1.21	4	

Quick change distance piece 50mm cpl. KF 600 21

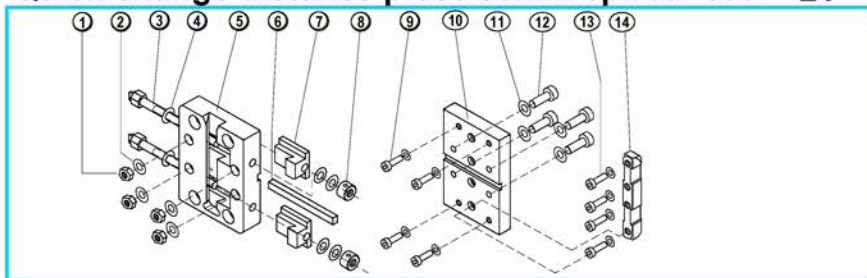

Item	Designation	Order no.	Piece	Price/Piece
	Ground drilling motor plate cpl.	600.1.19 K	1	
1	hexagonal self-locking nut M 8	250.3.14	4	
2	spring washer D 8	250.1.29	4	
3	clamping screw	250.1.15	2	
4	washer D 10	150.5.6	6	
5	groundplate housing	600.1.19	1	
6	feather 10x8x100 mm	250.1.19	1	
7	stretching block	250.1.16	2	
8	collar M 10	150.1.28	2	
9	hexagonal screw M 8x30	250.1.30	4	
	Drilling motor plate cpl.	600.1.18 BG K	1	
10	Drilling motor plate	600.1.18	1	
11	spring washer D 8	250.1.29	4	
12	hexagonal screw M 8x40	250.1.34	4	
13	hexagonal screw M 8x20 / 12.9	250.1.21	4	
14	clamping bolt	250.1.17	1	

Quick change distance piece 170mm cpl. KF 600

22

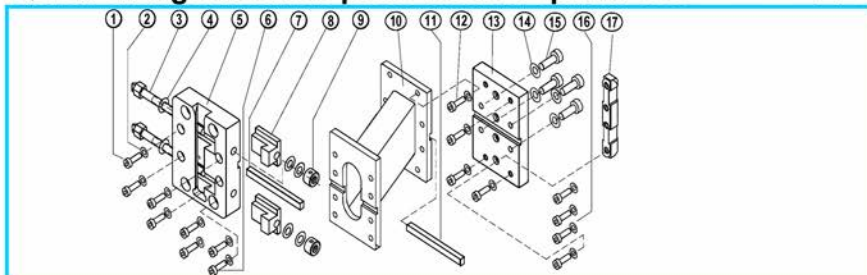

Item	Designation	Order no.	Piece	Price/Piece
	Ground drilling motor plate cpl.	600.1.19 K	1	
1	hexagonal screw M 8x30	250.1.30	4	
2	spring washer D 8	250.1.29	12	
3	clamping screw M 10x131	250.1.15	2	
4	washer D 10	150.5.6	6	
5	groundplate housing	600.1.19	1	
6	hexagonal screw M 8x25	150.1.30	4	
7	feather 10x8x100 mm	250.1.19	1	
8	stretching block	250.1.16	2	
9	collar M 10	150.1.28	2	
10	spacer body 120 mm	600.2.01	1	
	Drilling motor plate cpl.	600.1.18 BG K	1	
11	feather 10x8x100 mm	250.1.19	1	
12	hexagonal screw M 8x25	150.1.30	4	
13	Drilling motor plate	600.1.18	1	
14	spring washer D 8	250.1.29	12	
15	hexagonal screw M 8x22	150.1.31	4	
16	hexagonal screw M 8x20 / 12.9	250.1.21	4	
17	clamping bolt	250.1.17	1	

23 Instep neck adapter cpl. KF 600

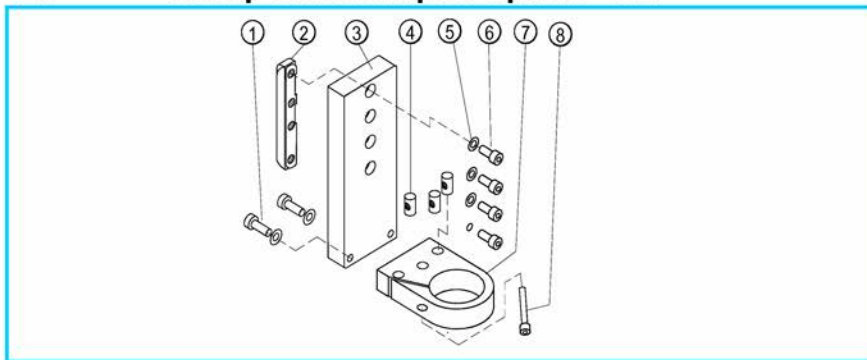

Item	Designation	Order no.	Piece	Price/Piece
1	hexagonal screw M 8x45	150.11.3	2	
2	straining beam	150.11.7	1	
3	instep neck adapter plate	150.11.2	1	
4	cross threaded bolts	150.11.5	3	
5	spring washer D 8	250.1.29	7	
6	hexagonal M 8x22	150.1.31	4	
7	instep neck adapter body	150.11.1	1	
8	hexagonal screw M 8x50	150.11.4	1	

24 Motor plate for Hilti Engines cpl. KF 600

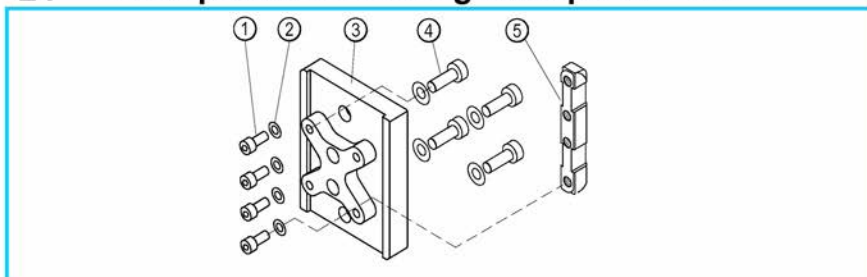

Item	Designation	Order no.	Piece	Price/Piece
1	hexagon socket screw M 8x20 / 12.9	250.1.21	4	
2	spring washer D 8	250.1.29	8	
3	Motor plate for Hilti Engines	400.1.18 H	1	
4	hexagon socket screw M 8x40 / 12.9	1000.11.2	4	
5	clamping bolt	250.1.17	1	

Drilling middles indicator cpl. KF 600 25

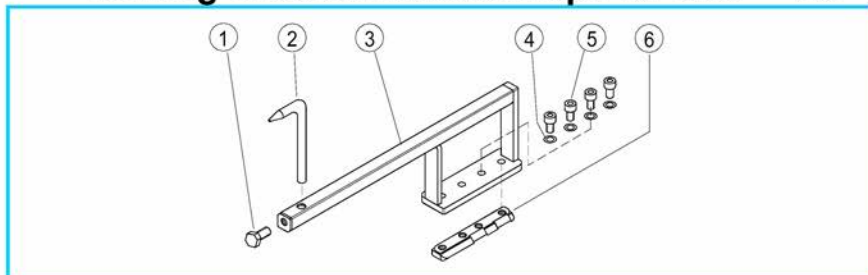

Item	Designation	Order no.	Piece	Price/Piece
1	screw M 10x20	250.10.4	1	
2	drilling middles indicator	250.10.5	1	
3	drilling middles indicator body	250.10.2	1	
4	spring washer D 8	250.1.29	4	
5	hexagonal screw M 8x18	150.1.21	4	
6	straining beam M 8x120	150.1.17	1	

End stop KF 600 26

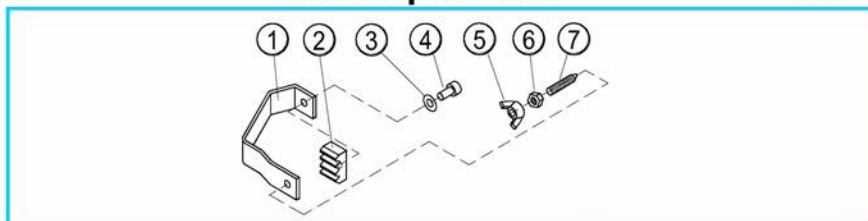

Item	Designation	Order no.	Piece	Price/Piece
1	end stop body 70x70mm	250.6.31	1	
2	gear rack Mo 2	250.6.32	1	
3	washer D 6	150.6.4	1	
4	hexagonal screw M 6x12	150.6.3	1	
5	thumb screw M 8	150.6.33	1	
6	hexagonnut flat M 8	150.6.34	1	
7	Hexagonthreaded screw M 8x25	150.6.35	1	



The company FleiKa Maschinen- und Anlagenbau GmbH & Co KG is a privately owned medium-sized family business in the plant and machinery sector. From years of experience in the field of concrete processing with diamond tools and machines, Mr. Kastner developed a novel roller guiding system for core drilling stands, which was granted patent protection in 1997. In 1995, Mr. Kastner decided to dissolve his drilling and sawing business and to found the company FleiKa Maschinen und Anlagenbau GmbH & Co KG.

By tapping into over 20 years of practical experience as an independent concrete driller, drill stand designer and manufacturer, Mr. Kastner, in time-consuming development efforts, has invented and constructed the distinctive, labour-saving parts.

Through his own daily work on the stands, the head of the company guarantees a sophisticated and unique quality product. New ideas for improving the stands are immediately realized and incorporated into the equipment. The family ensures a high level of service and continuity.

The originals - drill stand, accessories and spare parts - are only available through our **distribution partners**



Fleika Maschinen und Anlagenbau GmbH Co. KG

Koblberg 1, D-83564 Soyen, Vertrieb: Alois Blüml, Tel: 0049-8071-103228 - Fax: 0049-8071-103256